



FiberCUT[®] RAc

Laser Mechanisms' FiberCut[®] Right Angle, Compact (RAc) laser processing head collimates and focuses a fiber-delivered laser beam and directs it along with cutting gas through its nozzle for optimal metal cutting. FiberCut[®] RAc's nozzle also senses the required tip standoff from the workpiece and automatically maintains that distance through its internal drive system. The head's cover glass protects the cutting lens from process debris.

- 3-dimensional cutting with fiber-coupled laser for 16 kg robots
- Low moving mass minimizes inertia transfer to robot support arm
- Right angle entry of all connections, including fiber, provides tight access to parts, easy cable routing and stress reduction on input fiber
- Nearly 30 percent smaller and lighter than the original FiberCut[®] RA



Cartridge style drawer provides quick and easy access to the cover glass. Cleaning and replacement requires no tools and can be performed in a matter of seconds.



By locating all wiring and assist gas lines within the head, the potential for downtime due to snags and breaks is virtually eliminated.

Features

- Internal, low-noise height sensing system is insensitive to cutting plasma or piercing debris
- Z lens focus-to-tip adjustment
- X-Y beam-to-tip centering adjustment
- Works with all leading fiber-delivered laser systems up to 4 kW with wavelengths of 1064/1080 nm
- Complete system consists of cutting head, fiber collimator and linear drive with position measuring
- Cam-operated drive system with axial crash protection
- All wiring and assist gas lines are internally plumbed – avoiding costly snags and breaks
- Cartridge style drawer provides quick and easy access to the cover glass
- Provides error signals in case of collision, over-temperature and exceeding the operating range
- Sealed beam path
- Engineered for the harsh factory floor environment

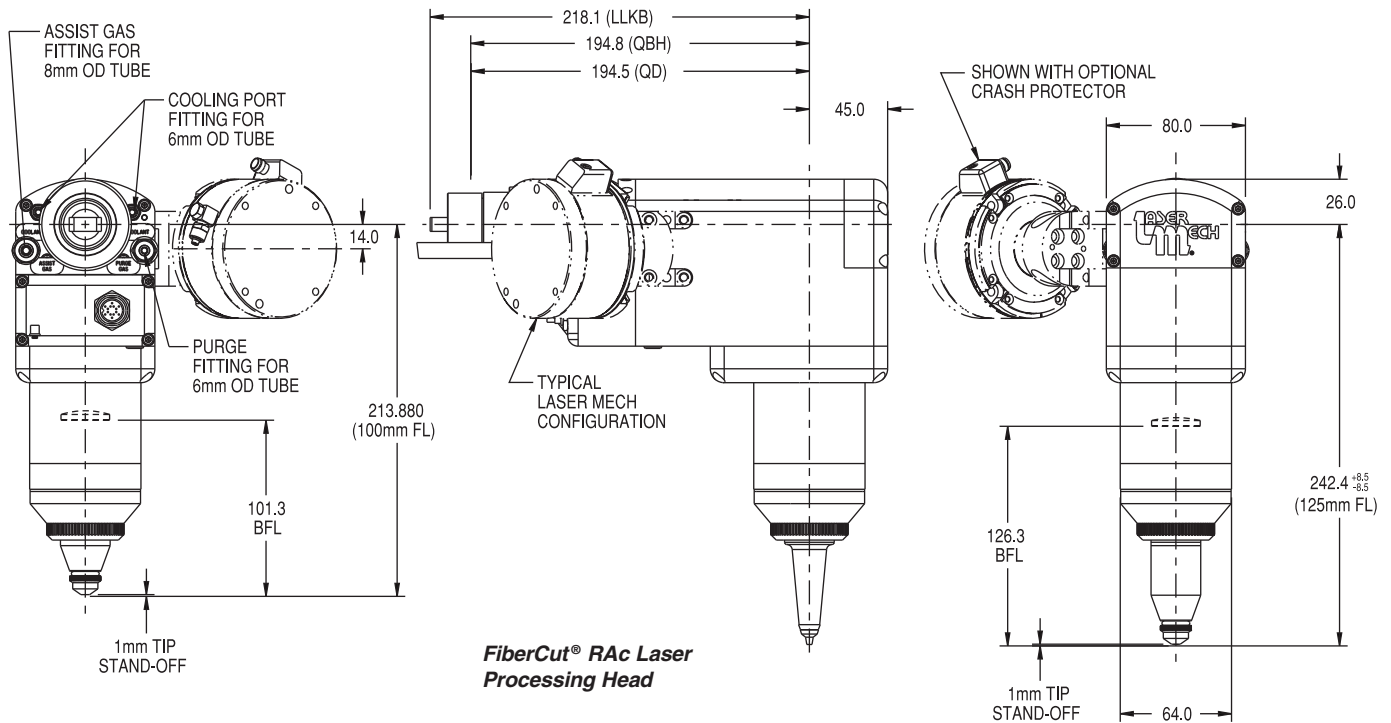

FiberCut® RAc Laser Processing Head

Specifications

CUTTING HEAD

Power Rating	up to 4 kW
Focusing Lens (Focal Length)	104 mm, 130 mm
Focusing Lens (Diameter)	28 mm
Clear Aperture	25 mm
Nozzle Tip (Various Shapes)	Cold Formed
Assist Gas Pressure	up to 20 BAR
Gas & Water Ports	6 mm tube to M5 fittings
Weight	3.2 kg
Height (Center Of Travel)	242.4 mm
Slide Travel	±8.5 mm
Max. Travel Speed	175 mm/sec.
Standoff Distance Range (1 mm Recommended)	0.3 mm to 4.0 mm

COLLIMATOR

Focal Lengths (Doublet, Fused Silica)	71 mm, 104 mm
Recollimating Lens (Diameter)	28 mm
Clear Aperture	25 mm
Fiber Socket (Others Available On Request)	QBH, LLK-B, QD

CONTROL BOX

Sealed Enclosure	380 mm L x 300 mm W x 160 mm H
Single Interconnect Cable	up to 15 m long
Number of Standoff Settings	7
Electrical Supply	85-264 VAC, 1-Phase, 47-63 Hz
Interface Inputs	5-24 VDC, 2.2 kΩ impedance, optically isolated
Interface Outputs	12-24 VDC, 150 mA max., sink/source, optically isolated

Specifications subject to change without notice.



Laser Mechanisms, Inc.
 25325 Regency Drive
 Novi, Michigan 48375
 Phone: (248) 474-9480
 Fax: (248) 474-9277

Laser Mechanisms Europe NV
 Groenestaakstraat 59
 B-9030 Mariakerke, Belgium
 Phone: +32 (0)92 18 70 70
 Fax: +32 (0)92 18 70 79

Internet
 Web: www.lasermech.com
 E-Mail: info@lasermech.com